

# Series **1100/AT1200**

- Grounds Maintenance • Restaurants/Hotels
- Washdown Operations • Home Use

**To handle 3/8" through 1" I.D. hose.**

- Continuous flow reels with swivel joint inlet, fluid hub, outlet riser.
- Direct crank rewind and cam-lock drag brake.
- One-piece foot and removable steel handlebar.
- **GH** prefix to model number (e.g., GH1100, GHAT1200) includes garden hose thread on outlet, 5' lead-in hose, hose end clips.

**Model 1100**

- Standard inlet: 90° ball bearing swivel joint, 1/2" female NPT threads.
- Standard outlet: 1/2" female NPT threads.
- Pressures to 3000 psi (207 bar).
- Temperatures from +20°F to +400°F (-7°C to +204°C).
- Rubber tires standard.

**Model AT1200**

- Standard inlet: 90° balance pressure swivel joint, 1" female NPT threads.
- Standard outlet: 1" female NPT threads.
- Standard pressures to 2000 psi (138 bar), available up to 4000 psi (276 bar) – must specify.
- Temperatures from -40°F to +250°F (-40°C to +121°C).
- Pneumatic tires standard.



GH1100 configuration shown in optional green powder coat finish



GHAT1200 configuration shown

**PARTS DRAWING – 1100–ISO 48; AT1200–ISO 87**

Model Number	Hose Capacity of Reel feet m						Approx. Weight lb. kg		Reel Dimensions in. mm							
	I.D. in. mm	3/8 10	1/2 13	5/8 16	3/4 19	1 25	NET	SHIP	A	B	C	D	E	F	G	H
	O.D. in. mm	3/4 19	7/8 22	1 25	1-9/32 33	1-1/2 38										
<b>1100</b>		<b>275</b> 84	<b>175</b> 53	<b>125</b> 38	-	-	<b>47</b> 21	<b>100*</b> 46	<b>21.5</b> 548	<b>12</b> 305	<b>6</b> 152	<b>21</b> 533	<b>16.5</b> 419	<b>25.38</b> 645	<b>39</b> 991	<b>13.81</b> 351
<b>AT1200</b>		-	<b>350</b> 107	<b>250</b> 78	<b>150</b> 46	<b>100</b> 30	<b>86</b> 39	<b>147*</b> 67	<b>24.88</b> 632	<b>11.5</b> 292	<b>8</b> 203	<b>23.31</b> 592	<b>22.75</b> 578	<b>27.25</b> 692	<b>40</b> 1016	<b>17.25</b> 438

**Notes:**

1. Specifications subject to change.
  2. Some assembly required.
  3. **Finish:** Refer to page 3.
  4. **Be sure to check dimensions and weights prior to ordering.**
- \*Dimensional weight applies when shipped as a parcel package (via FedEx or UPS Ground).

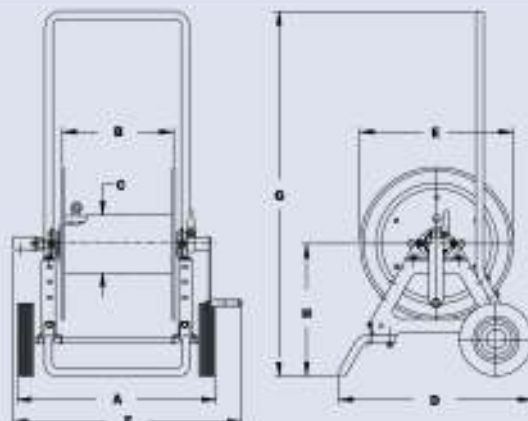

GH1100 shown